

❖ Spider Robot

ID MAP

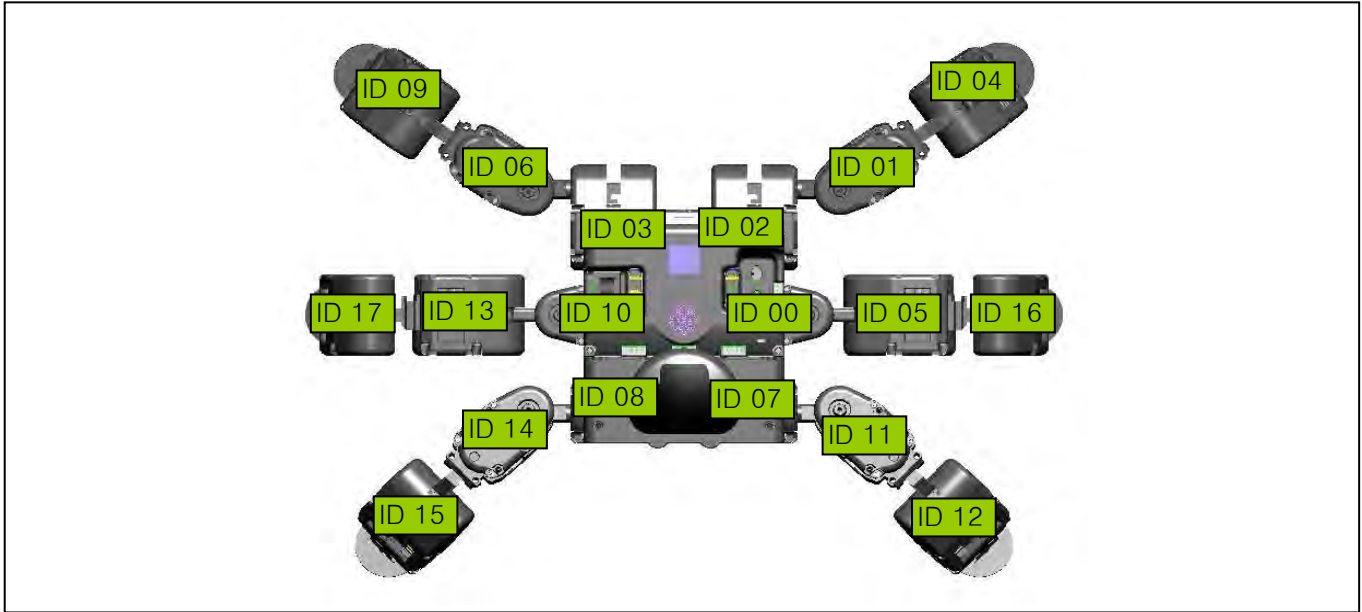

Part List

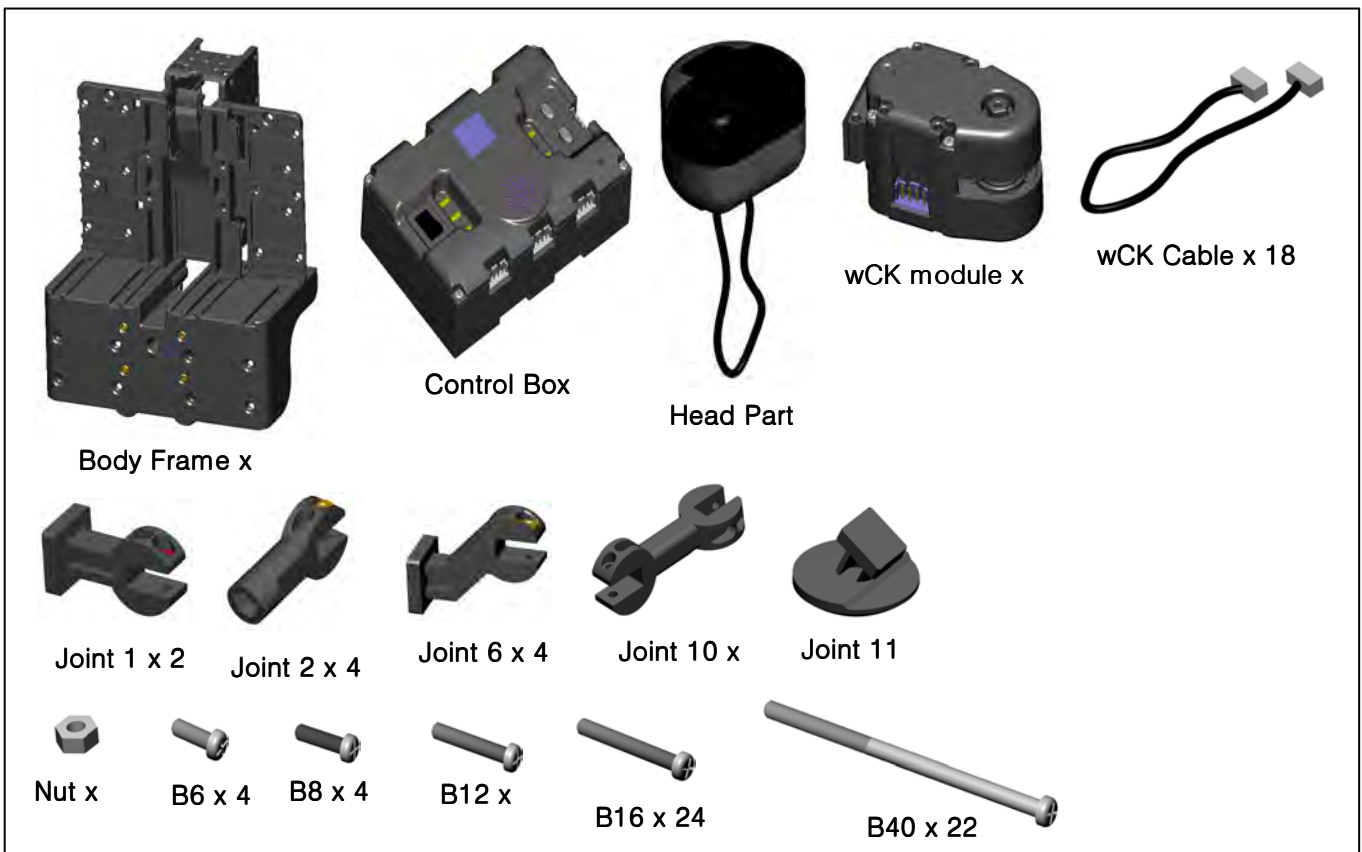

## STEP 01

### Sensor

Bolt M2x6L : 4EA

Nut M2 : 4EA

Bolt M2x12L : 2EA

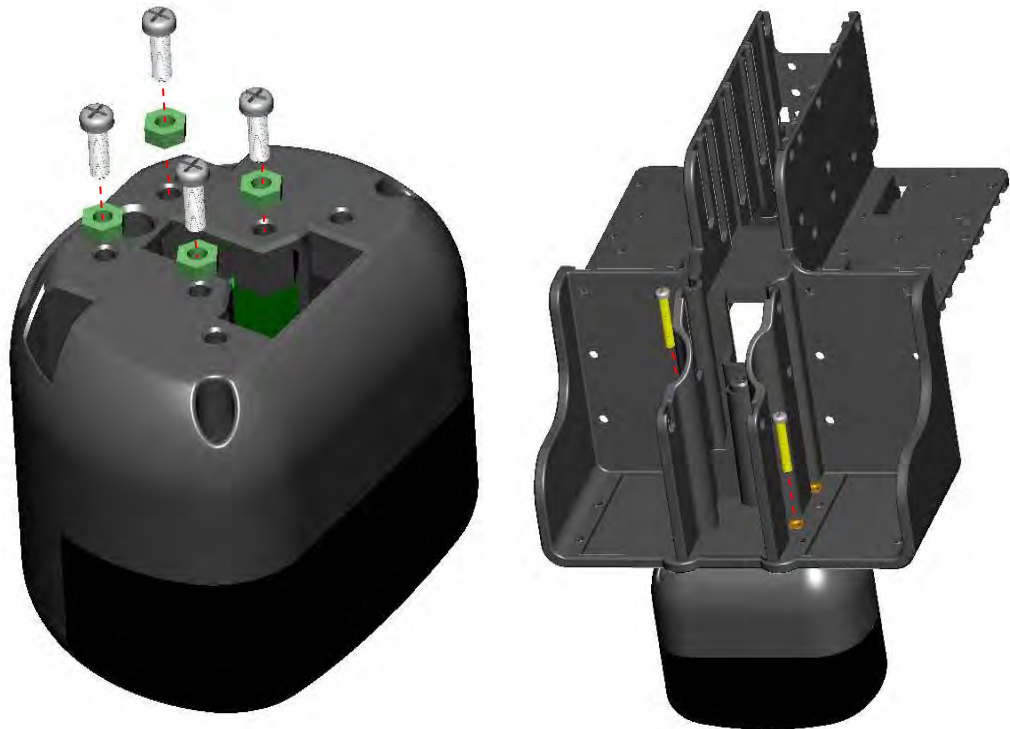

## STEP 02

### Left Leg

Bolt M2x40L : 3EA

Nut M2 : 3EA

Bolt M2x8L : 1EA

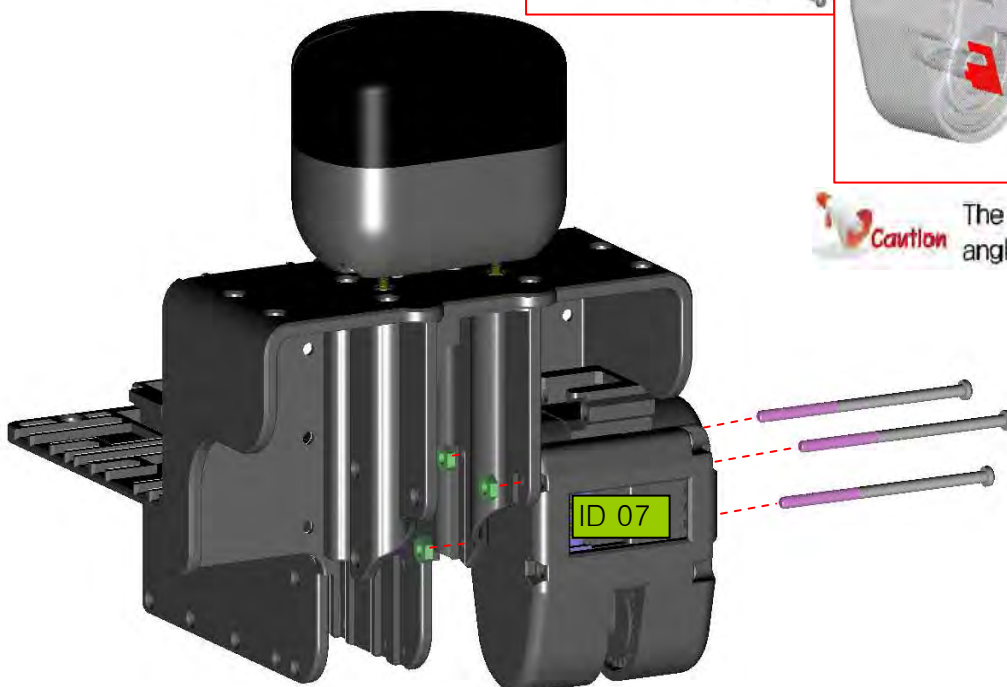

The adjustment of the connecting angle is critically important.

## STEP 03

### Left Leg

Bolt M2x16L : 4EA
Nut M2 : 4EA
Bolt M2x12L : 2EA

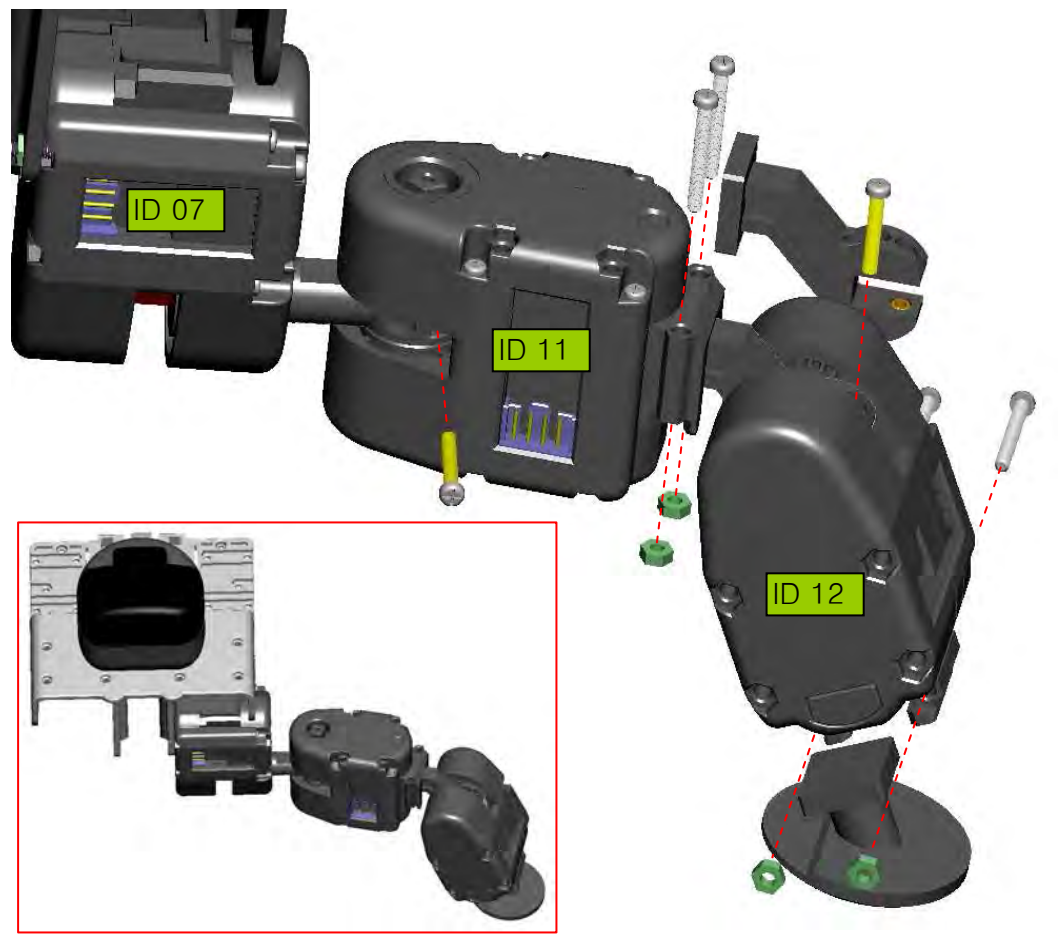

## STEP 04

### Right Leg

Bolt M2x40L : 3EA
Nut M2 : 3EA
Bolt M2x8L : 1EA

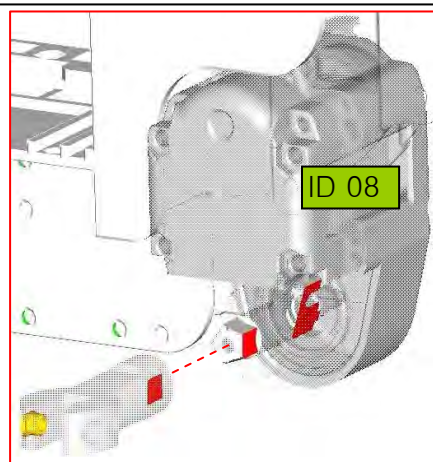

The adjustment of the connecting angle is critically important.

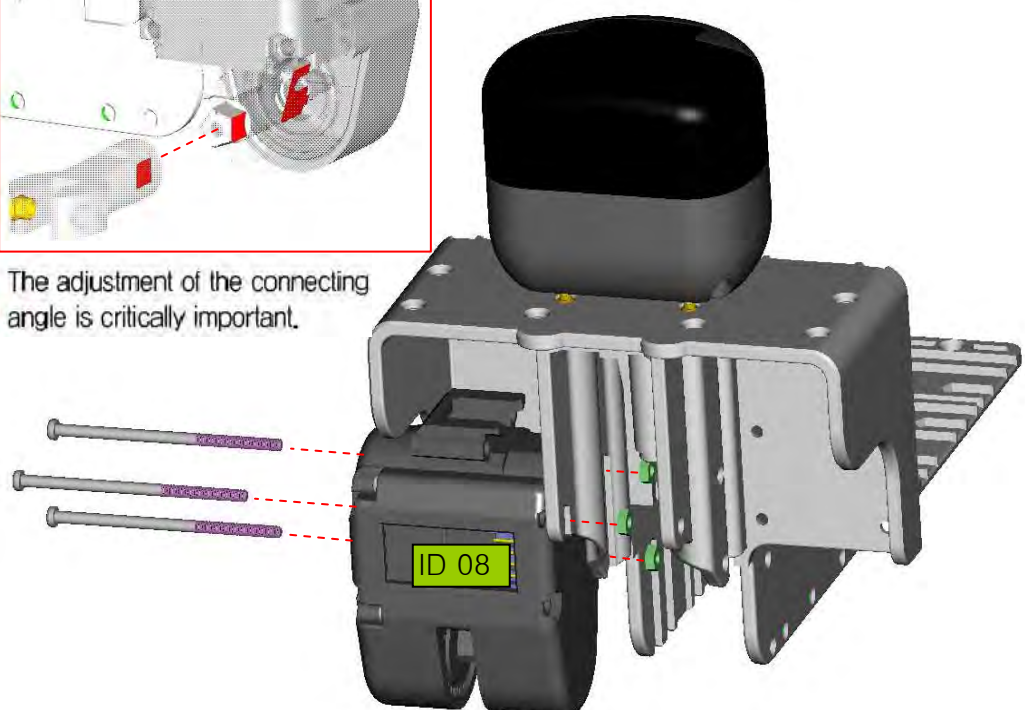
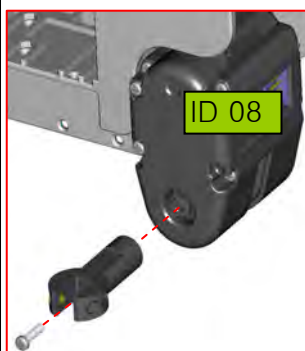

## STEP 05

### Right Leg

Bolt M2x16L : 4EA

Nut M2 : 4EA

Bolt M2x12L : 2EA

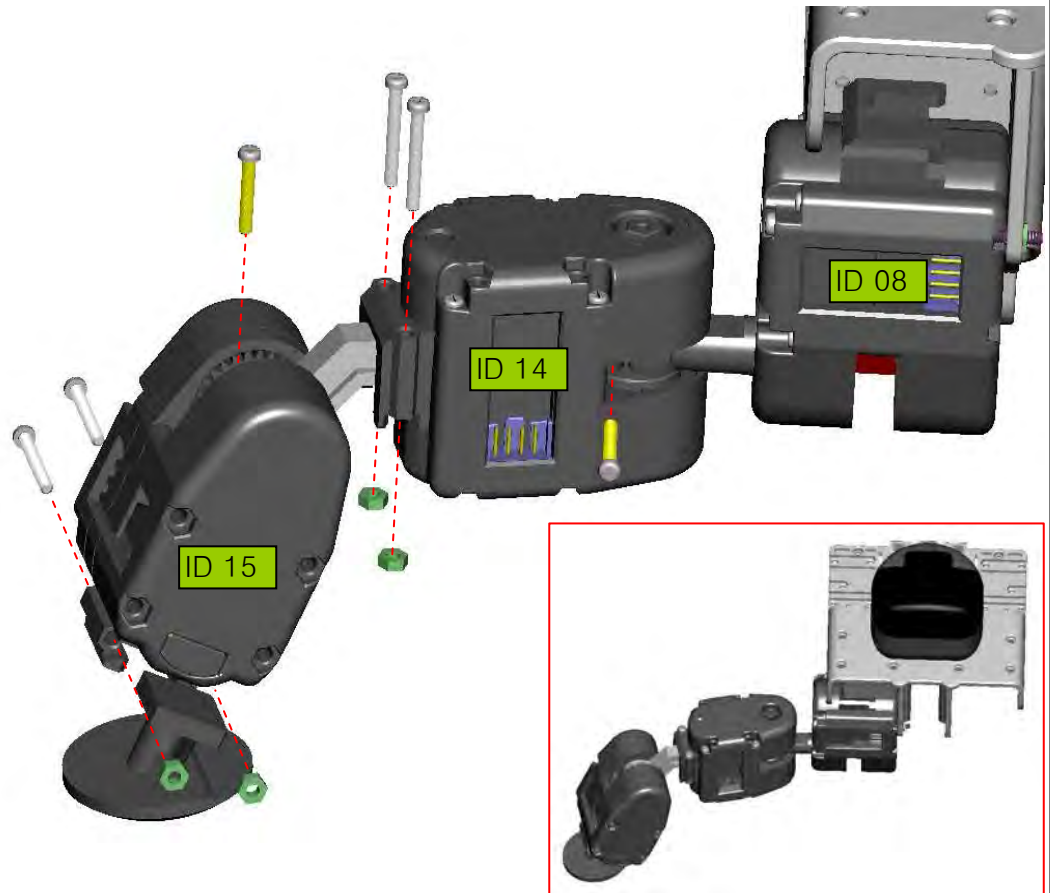

## STEP 06

### Middle Leg

Bolt M2x40L : 3EA

Nut M2 : 11EA

Bolt M2x12L : 3EA

Bolt M2x16L : 4EA

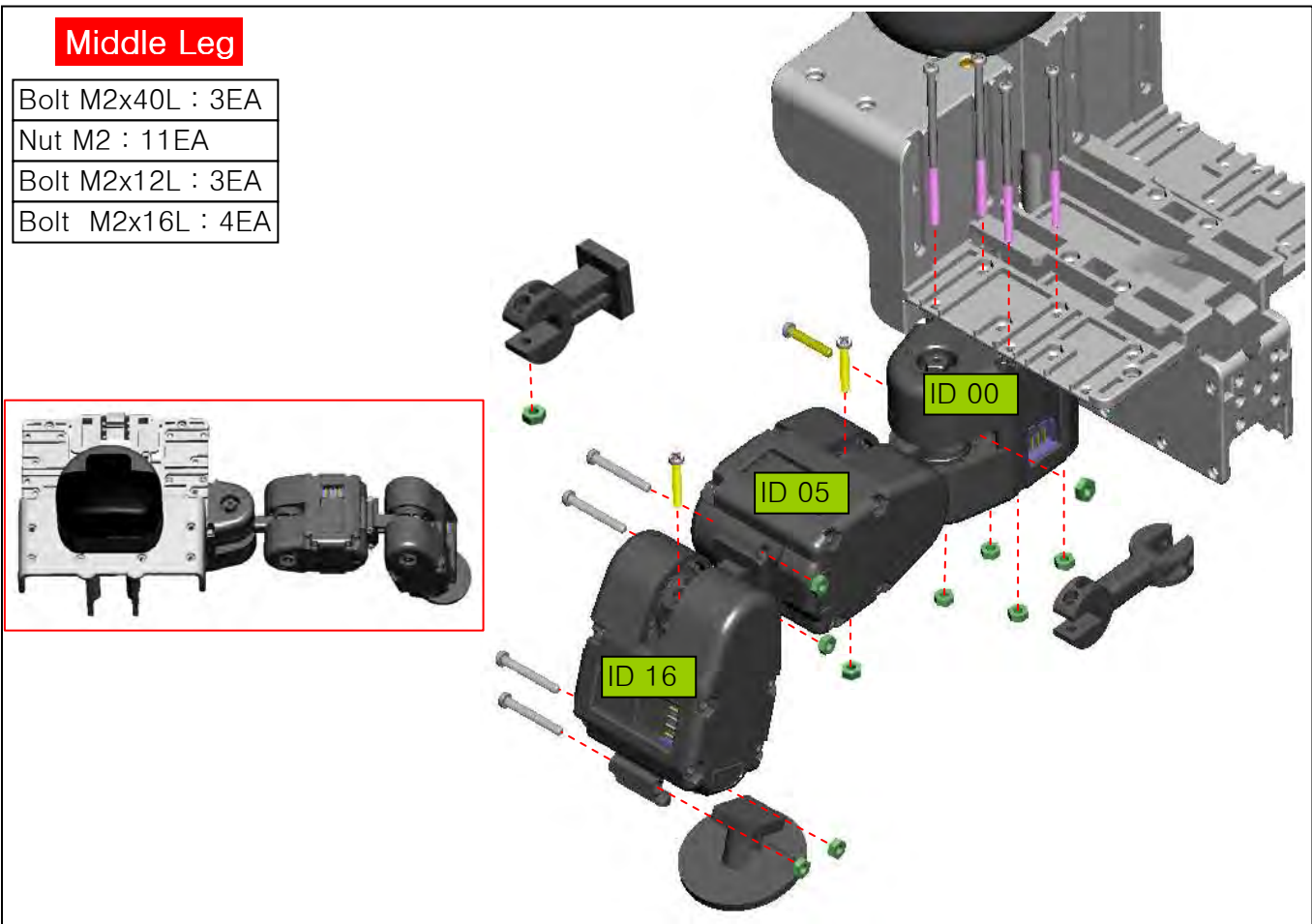

## STEP 07

### Middle Leg

Bolt M2x40L : 4EA
Nut M2 : 11EA
Bolt M2x12L : 3EA
Bolt M2x16L : 4EA

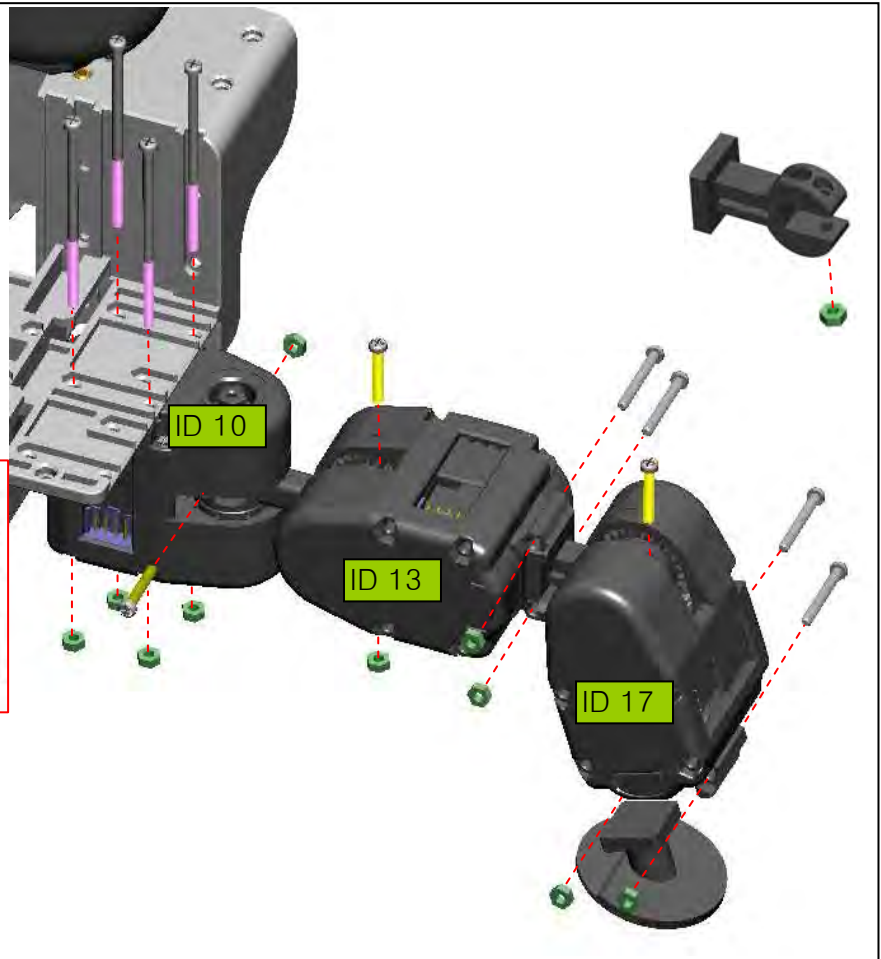
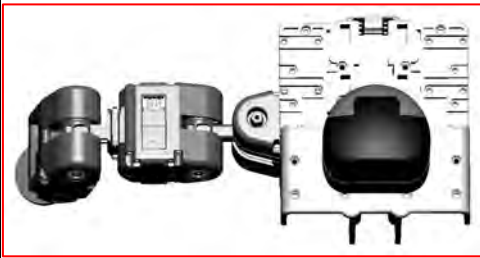

## STEP 08

### Left Leg

Bolt M2x40L : 4EA
Nut M2 : 4EA
Bolt M2x8L : 1EA

 **Caution** The adjustment of the connecting angle is critically important.

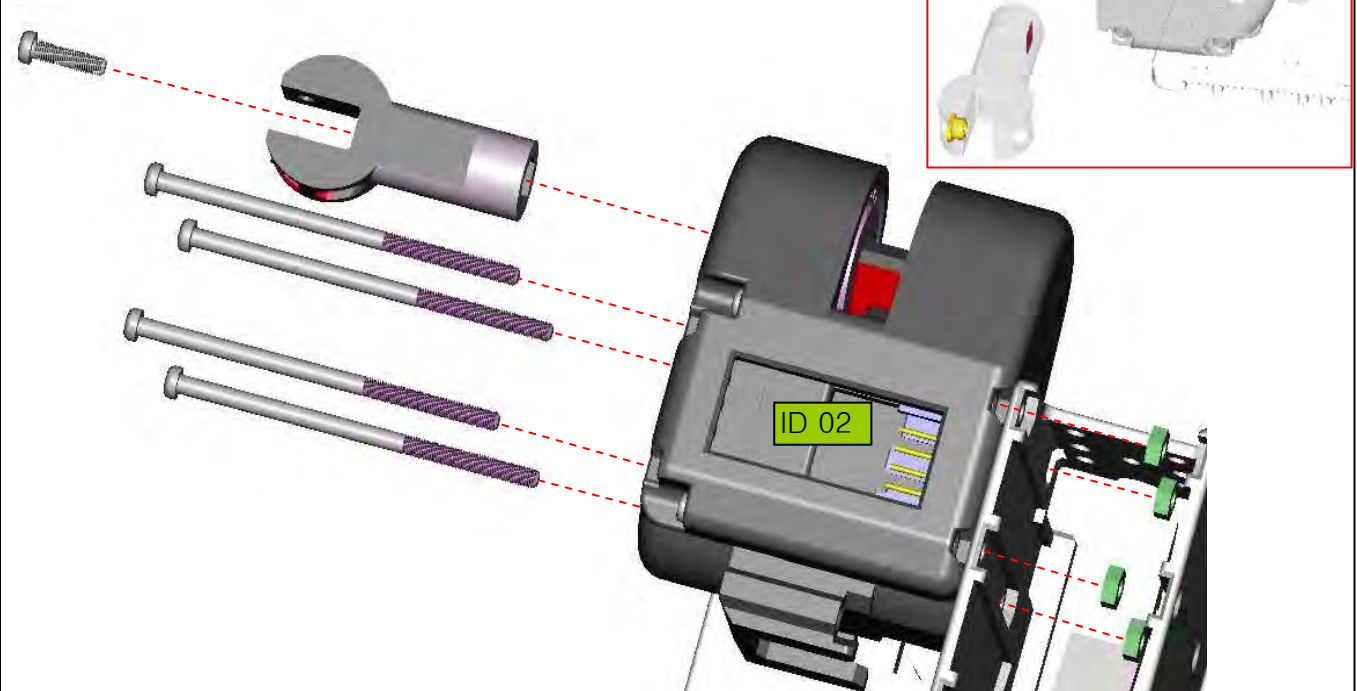
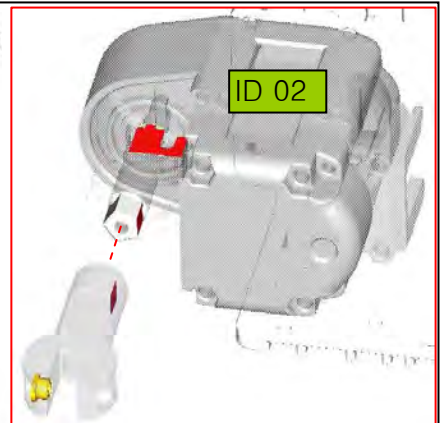

## STEP 09

### Left Leg

Bolt M2x16L : 4EA

Nut M2 : 4EA

Bolt M2x12L : 2EA

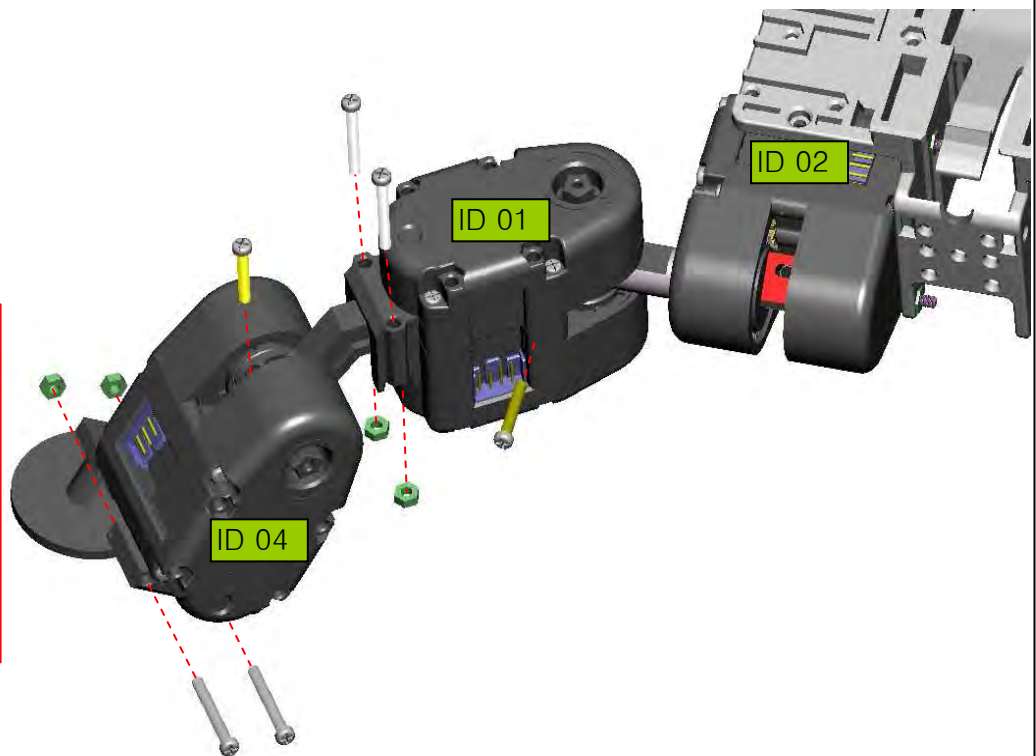

## STEP 10

### Right Leg

Bolt M2x40L : 4EA

Nut M2 : 4EA

Bolt M2x8L : 1EA



The adjustment of the connecting angle is critically important.

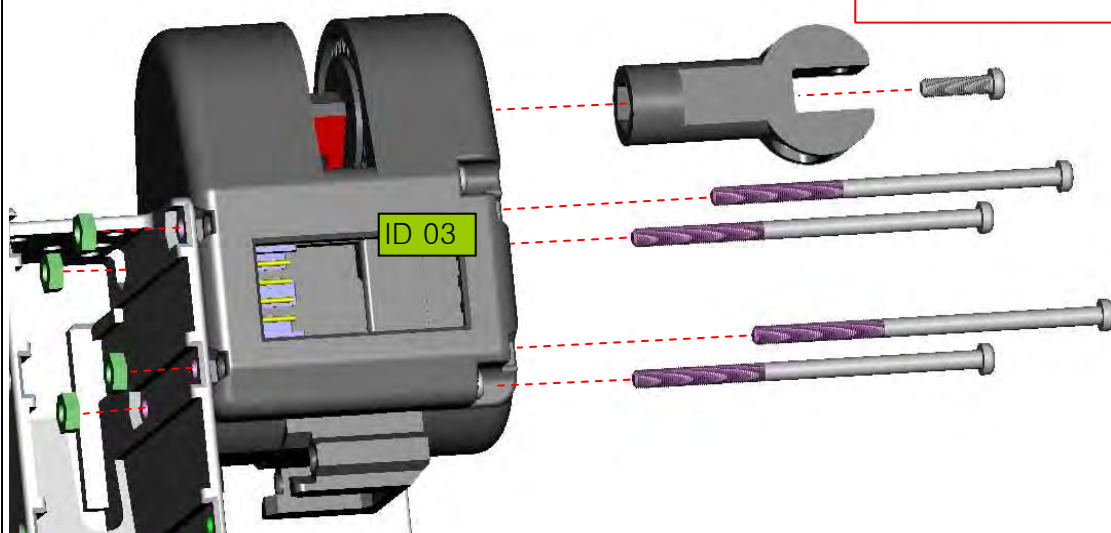
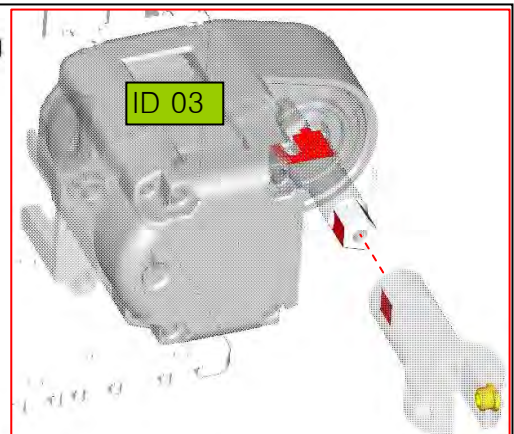

## STEP 11

### Right Leg

Bolt M2x16L : 4EA

Nut M2 : 4EA

Bolt M2x12L : 1EA

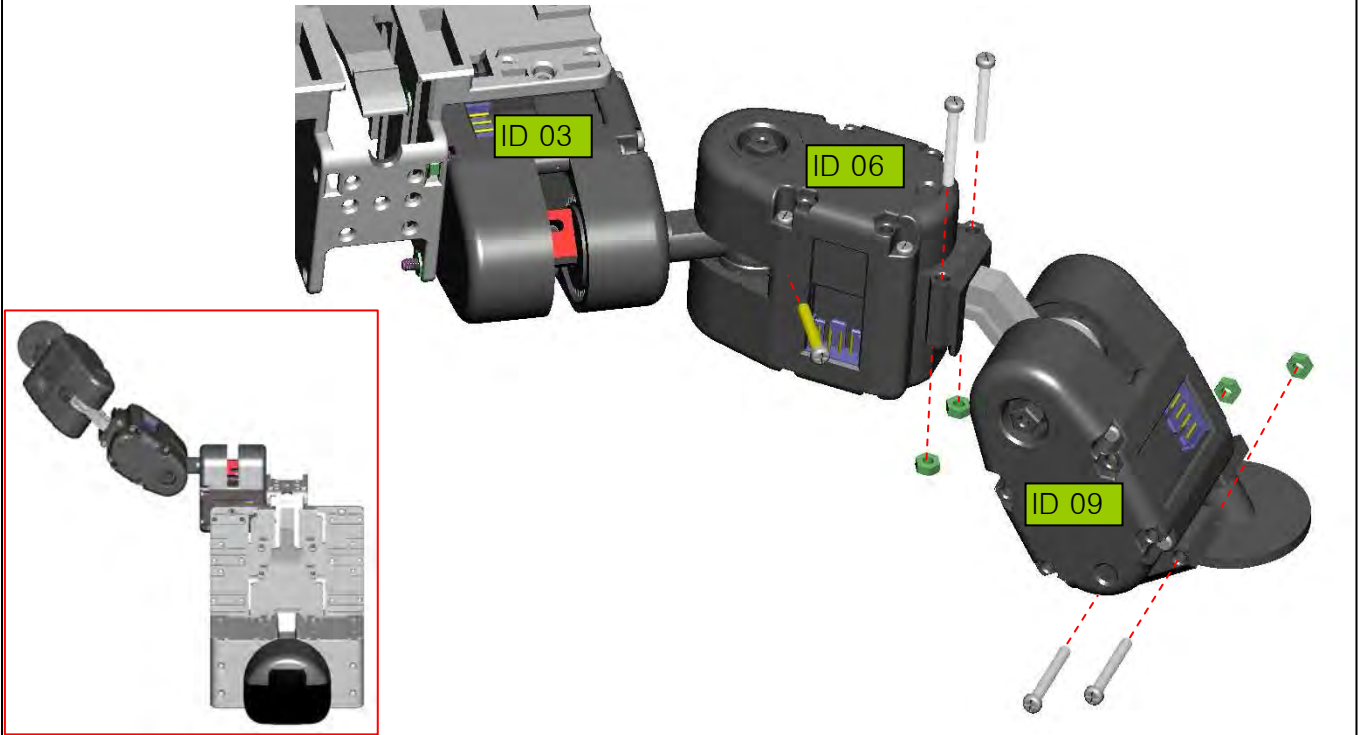

## STEP 12

### RBC

